

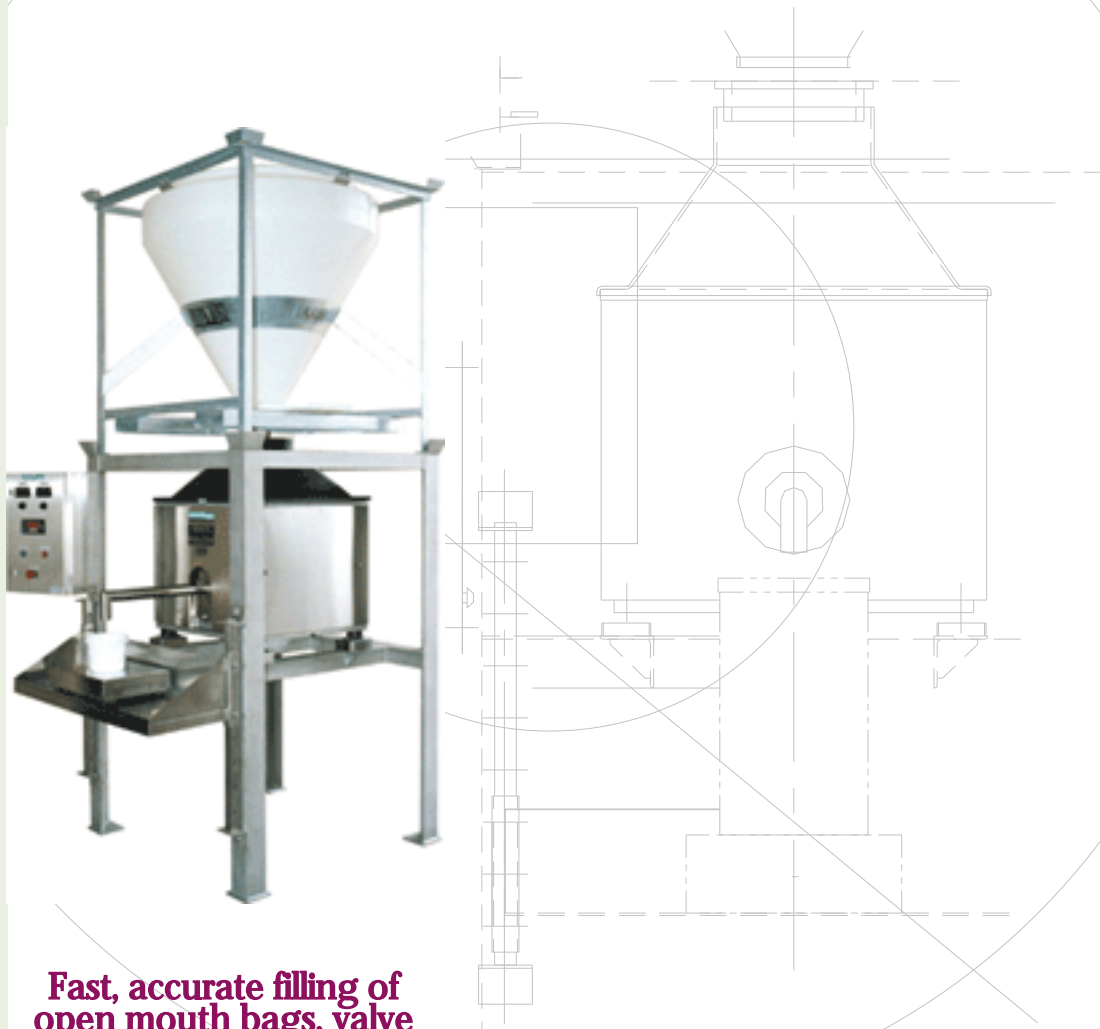

Powder Filling System

Model FS-750



**Fast, accurate filling of
open mouth bags, valve
bags, jars, containers,
pails and boxes.**



KLAUSENER | PROCESS MACHINERY | PTY. LTD.

20 BESSEMER STREET, BLACKTOWN NSW 2148 AUSTRALIA
TEL: (61 2) 9672 - 3222 FAX: (61 2) 9672 - 8733
E - MAIL: sales@kpm.com.au WEBSITE: www.kpm.com.au



Powder Filling System

Model FS-750

Fast, accurate filling of open mouth bags, valve bags, jars, containers, pails and boxes.

The Duraflex™ Filling System model FS -750 is a versatile filling system suited to a wide variety of filling applications. The system utilises a special massaging system on the walls of the infeed hopper to prevent bridging and product hang up, to give accurate filling of even the most difficult product.

The filling system is easy to use and is designed for fast clean-down. The one system is capable of a wide range of filling capacities ranging from 50g to over 50kg by quickly changing the size of the filling nozzle.

The weighing system is based on a sophisticated yet easy to use Ranger 5100 controller system that allows the operator to set target weight, dribble feed and in-flight compensation to achieve weight accuracy of $\pm 0.5\%$.

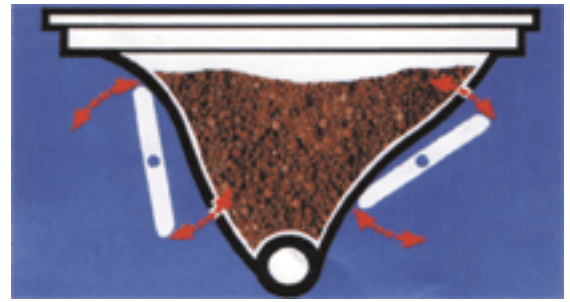

Massaging system on walls of infeed hopper

A



Duraflex Feeder

B



Disassembled Feeder

C

Ranger 5100 Controller



D

The Duraflex™ Filling System can fill a variety of containers including open mouth bags, valve bags, jars, containers, buckets and boxes. Its ability to handle all types of powders, granules, nuts, or even make it suited to almost any application.

Coupled with the Durabin mini bulk bins (optional), material can be easily and quickly fed into the filling system, reducing dust.

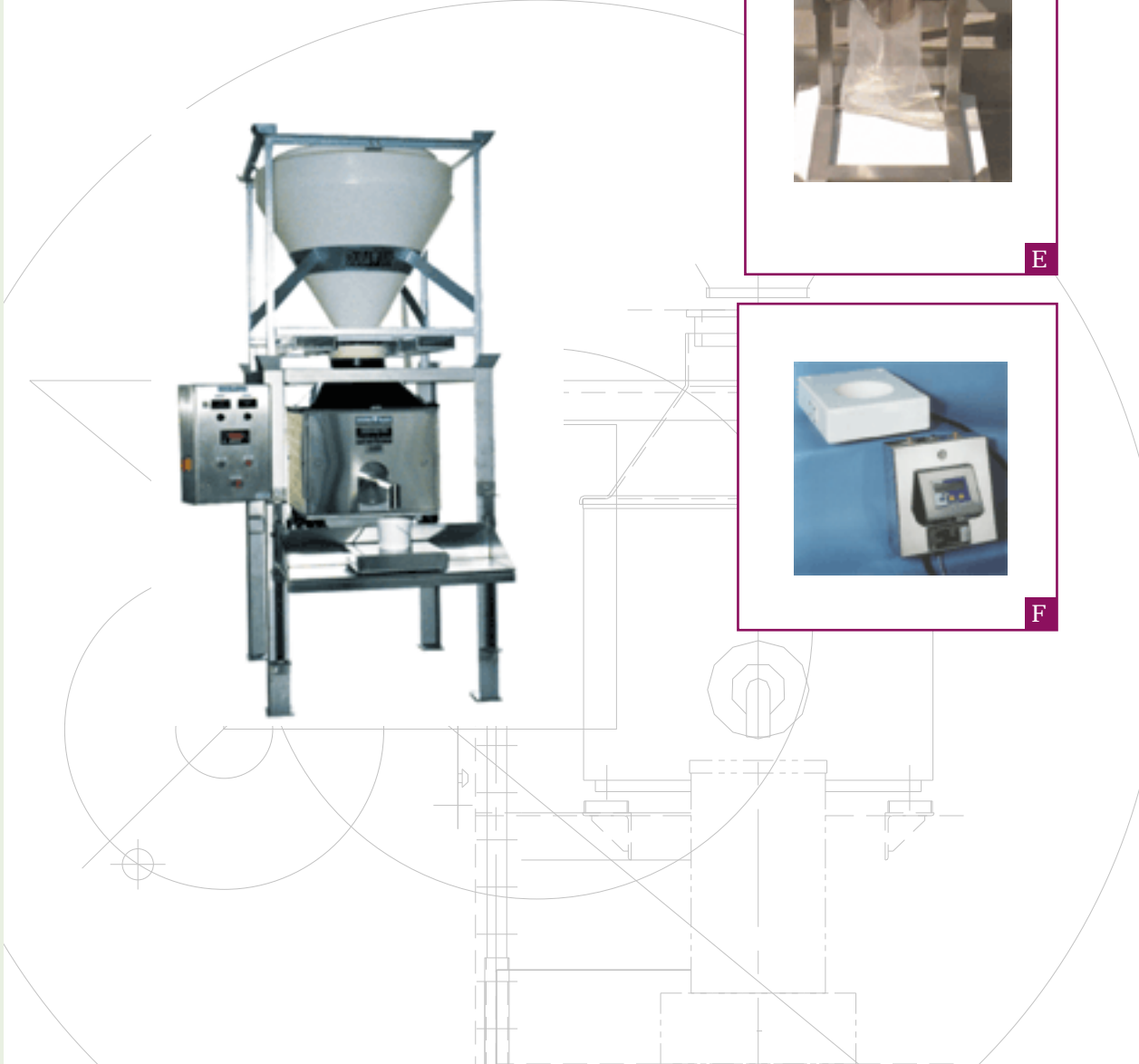

Optional Features:

E Bag Clamping Device

F Metal Detector



